

# Temperature sensor type CT GN1

now available with  
**BV marine certificate**

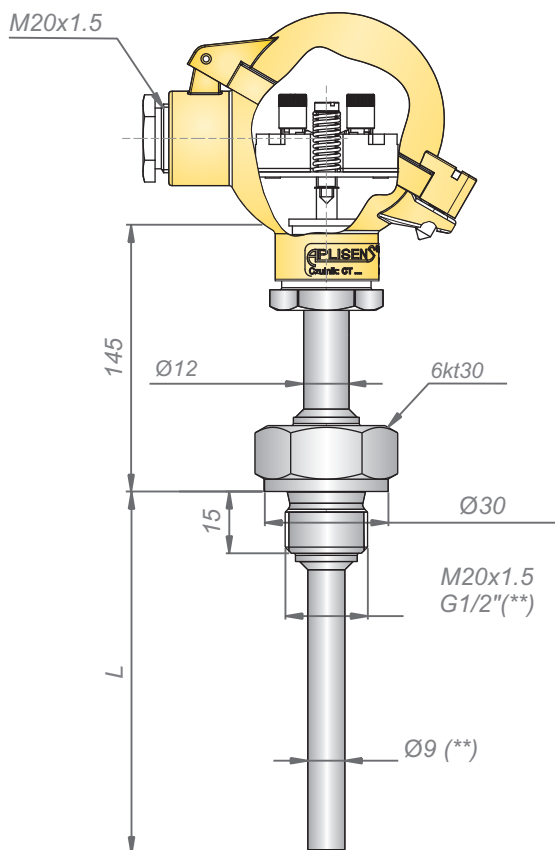

## TECHNICAL DATA:

- Measuring range:  
Pt: -70...500°C / -196...150°C (\*)  
J/K: -40...550°C / -200...550°C
- Admissible load:  
see **Graph 2** (page X/ 17)
- Material of wetted parts:  
304ss or 316Lss (\*\*)
- Standard immersion length  
L=100, 160, 250, 400 mm (\*\*)
- Process connection:  
M20x1.5 or G1/2(\*\*)
- Time constant:

Pt	T <sub>0.5</sub> [s]	T <sub>0.9</sub> [s]
	≤ 33	≤ 95

J/K	Isolated junction		Grounded junction	
	T <sub>0.5</sub> [s]	T <sub>0.9</sub> [s]	T <sub>0.5</sub> [s]	T <sub>0.9</sub> [s]
	≤ 22	≤ 62	≤ 3	≤ 8

- Diameter of the measuring insert:  
Ø 6 mm
- Minimal immersion depth:  
Pt: 90 mm

Ex I M1 Ex ia I Ma

Ex II 1/2 G Ex ia IIC T6..T1 Ga/Gb  
II 1D Ex iaD 20 T75°C Da

## Ordering procedure with example of ordering code:

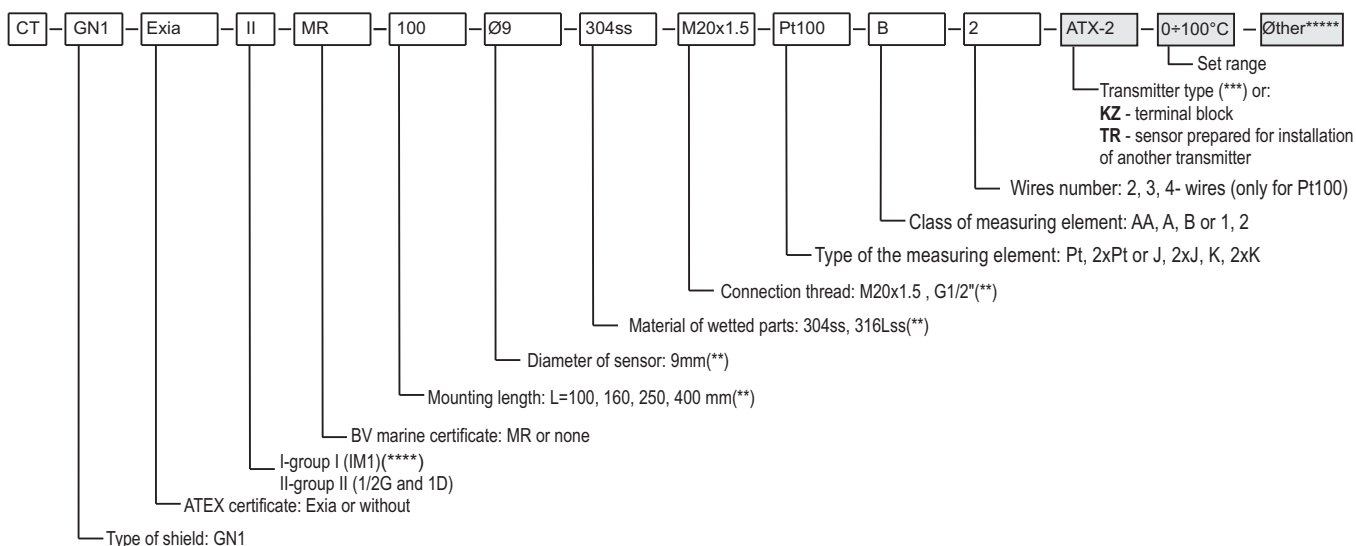

## ADDITIONAL INFORMATION:

- (\*) Low temperature version: -196...150°C.
- (\*\*) Non-standard version of temperature sensors on request.
- (\*\*\*) Type of temp. transmitters: LI24-G, AT-2, GI-22-2, ATX-2, GIX-22-2 or other.
- (\*\*\*\*) Temperature sensor for group I is produced with stainless steel housing.
- (\*\*\*\*\*) Additional required parameters acc. to transmitter data sheet.