

APLISENS®

USER'S MANUAL

PRESSURE TRANSMITTERS

PCE-28

DIFFERENTIAL PRESSURE TRANSMITTERS

PRE-28

AND HYDROSTATIC LEVEL PROBES

PCE-28P

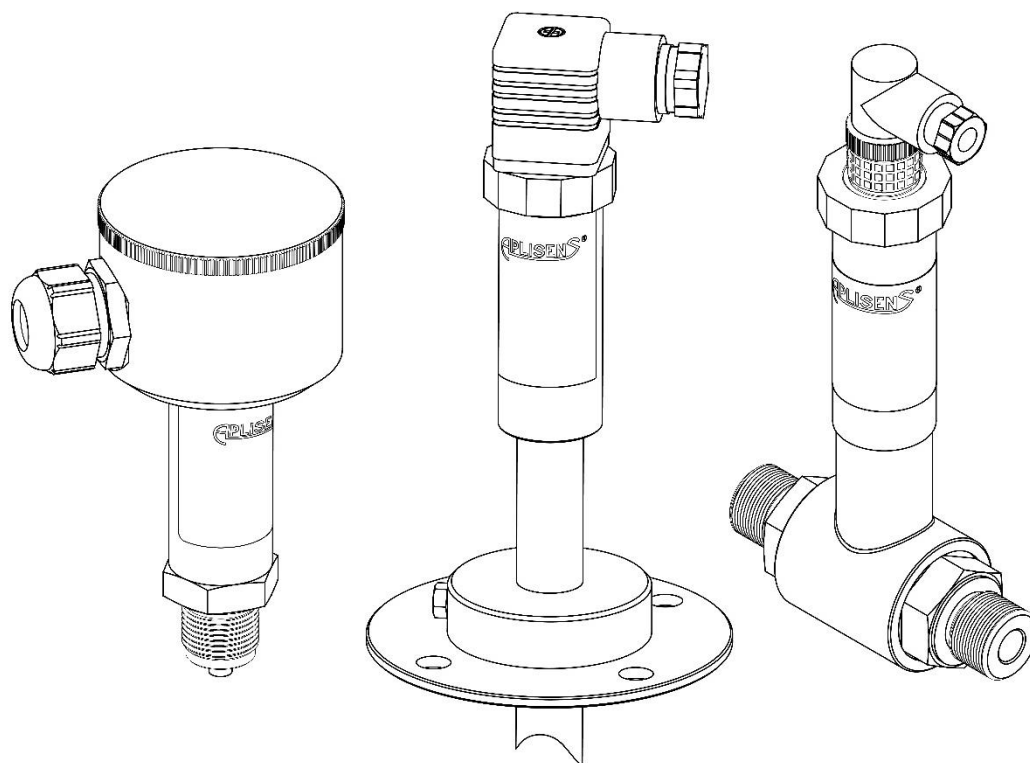

PRODUCT CODE – see: (→ [Transmitter identification](#)).

The QR code or ID number identifies the transmitter and provides quick access to the following documentation on the manufacturer’s website: user’s manual, declarations of conformity and copies of certificates.

PCE-28

<https://www.aplisens.pl/ID/0030000100000000000000000000147/>

ID: 0030 0001 0000 0000 0000 0000 0000 0001 47

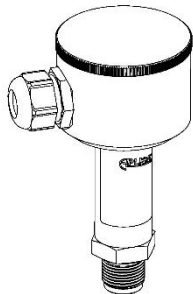

PCE-28 (Exi)

<https://www.aplisens.pl/ID/0030000200000000000000001000164/>

ID: 0030 0002 0000 0000 0000 0000 0001 0001 64

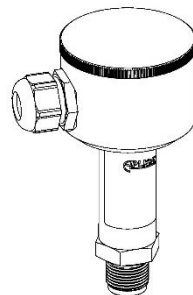

PRE-28

<https://www.aplisens.pl/ID/0035000100000000000000000000132/>

ID: 0035 0001 0000 0000 0000 0000 0000 0001 32

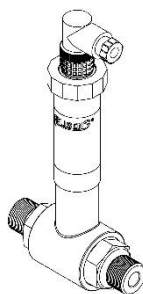

PRE-28 (Exi)

<https://www.aplisens.pl/ID/0035000200000000000000001000149/>

ID: 0035 0002 0000 0000 0000 0000 0001 0001 49

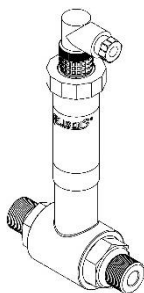

PCE-28P

<https://www.aplisens.pl/ID/005400010000000000000000000000172/>

ID: 0054 0001 0000 0000 0000 0000 0001 72

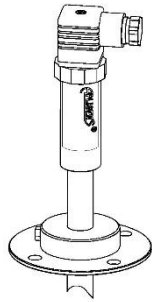



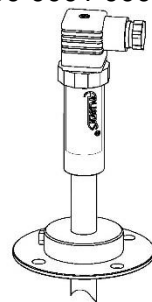

PCE-28P (Exi)

<https://www.aplisens.pl/ID/0054000200000000000000001000189/>

ID: 0054 0002 0000 0000 0000 0000 0001 89



Symbols used

Symbol	Description
	Warning to proceed strictly in accordance with the information contained in the documentation in order to ensure the safety and full functionality of the device.
	Information particularly useful during installation and operation of the device.
	Information particularly useful during installation and operation of an Ex type device.
	Information on disposal of used equipment.

BASIC REQUIREMENTS AND SAFE USE



The manufacturer will not be liable for damage resulting from incorrect installation, failure to maintain a suitable technical condition of the device or use of the device other than for its intended purpose.

Installation should be carried out by qualified staff having the required authorizations to install electrical and I&C equipment. The installer is responsible for performing the installation in accordance with manual as well as with the electromagnetic compatibility and safety regulations and standards applicable to the type of installation.

In systems with I&C equipment, in case of leakage, there is a danger to staff due to the medium under pressure. All safety and protection requirements must be observed during installation, operation and inspections.

If a malfunction occurs, the device should be disconnected and handed over to the manufacturer for repair.



In order to minimize the risk of malfunction and associated risks to staff, the device is not to be installed or used in particularly unfavourable conditions, where the following hazards occur:

- possible mechanical impacts, excessive shocks and vibration;
- excessive temperature fluctuation;
- water vapour condensation, dusting, icing.

Changes made to the manufacturing of products may be introduced before the paper version of the manual is updated. The up-to-date manuals are available on the manufacturer's website: www.aplisens.com.

I. APPENDIX Ex.01 20
II. APPENDIX Ex.02 25

LIST OF DRAWINGS

Figure 1. Rotation of the housing, change of display position and access to buttons.....14
Figure 2. Display information fields.....15
Figure 3. Backlighting jumper view at transmitter electric board (unit display back side).15
Figure 4. Diagram of the display menu (applies to ALW and ALM versions).....17

LIST OF TABLES

Table 1. Symbols appearing on the transmitter's nameplate.....9
Table 2. Connection for the current version.11
Table 3. Connection for the voltage version.....11
Table 4. Permissible transmitter supply voltages.13

1. INTRODUCTION

1.1. Purpose of the document

The subject of manual are pressure transmitters **PCE-28**, differential pressure transmitters **PRE-28** and hydrostatic level probes **PCE-28P**. The manual applies to the following versions: standard, intrinsically safe Exi and PED version.

Within the meaning of Directive 2014/68/EU (PED), the transmitters are designed to category I, module A. PED marking does not apply to additional equipment of the transmitters, i.e. separators, valves, connectors, impulse tubes, etc. In the manufacturer's EU declarations of conformity, the transmitters as designed above have the CE markings. The transmitters with permissible pressure 200 bar and lower are manufactured in accordance with good engineering practice according to article 4 point 3 of Directive 2014/68/EU.

The pressure transmitters: **PCE-28**, **PCE-28P**, **PRE-28** in realization for sea uses are complied with DNV-GL Rules for Classification of Ships, High Speed & Light Craft acc. to DNV Standard for Certification No. 2.4, April 2006, in following Location Classes:

- Temperature: D;
- Humidity: B;
- Vibrations: B;
- EMC: B;
- Enclosure: C.

The transmitters: **PCE-28**, **PCE-28P**, **PRE-28** in realization for sea uses are complied with Bureau Veritas (BV) for Classification of Ships, High Speed & Light Craft acc. to the requirements of NR320 for HBV products).

The manual contains data, tips and general recommendations for safe installation and operation of the transmitters, as well as troubleshooting in case of possible failure.



Data on the **PCE-28**, **PRE-28** transmitters and **PCE-28P** probes in intrinsically safe version according to IECEx and ATEX are included in the appendices marked as APPENDIX Ex.01 and APPENDIX Ex.02.

2. SAFETY



- The installation and start-up of the device and any activities related to operation shall be carried out after thorough examination of the contents of user's manual and the instructions related thereto;
- installation and maintenance should be carried out by qualified staff having the required authorizations to install electrical and measuring devices;
- the device shall be used according to its intended purpose in line with the permissible parameters specified on the nameplate (→ [Transmitter identification](#));
- the protection elements used by the manufacturer to ensure transmitter safety may be less effective if the device is operated in a manner not consistent with its intended purpose;
- before installing or disassembling the device, it is absolutely necessary to disconnect it from the power source;
- no repairs or alterations to the transmitter electronic system are permitted. Assessment of damages and possible repair may only be performed by the manufacturer or authorized representative;
- do not use instruments if damaged. In case of malfunction, the device must be put out of operation;
- in case of transmitters equipped with factory-mounted process connector of C and CR type, it is unacceptable to loosen the fixing screws of the connector cover.

3. TRANSPORT AND STORAGE

3.1. Delivery check

After receiving the delivery, please refer to the general terms and conditions of contracts available on the manufacturer website: https://aplisens.com/ogolne_warunki_umow.html

3.2. Transport

Transport of transmitters and probes shall be carried out with the use of covered means of transport, in original packages with diaphragm provided with protection. The packaging shall be protected against movement and direct impact of atmospheric factors.

3.3. Storage

Transmitters and probes shall be stored in a factory packaging, in a room without vapours and aggressive substances, protected against mechanical impact.

Allowable range of storage temperature:

- PCE-28 -40 ... 80°C (-40...176°F);
- PRE-28 -25 ... 80°C (-13...176°F);
- PCE-28P -25 ... 80°C (-13...176°F).



The operating temperature range and the measured medium for transmitters in Ex version according to APPENDIX Ex.01 and APPENDIX Ex.02.

4. GUARANTEE

General terms and conditions of guarantee are available on the manufacturer's website: www.aplisens.com/ogolne_warunki_gwarancji



The guarantee shall be repealed if the device is used against its intended use, failure to comply with user's manual or interference with the structure of the device.

5. IDENTIFICATION

5.1. Manufacturer's address

APLISENS S.A.
03-192 Warsaw
Morelowa 7 St.
Poland

5.2. Transmitter identification

Depending on the version of the transmitter, the nameplates may differ in the amount of information and parameters.

Table 1. Symbols appearing on the transmitter's nameplate

	Logo and name of manufacturer
	CE mark
	CE with number notified body
03-192 WARSZAWA Morelowa 7 Poland tel.: +48 22 814 07 77	Manufacturer's address
	QR code
TYPE:	Transmitter, electrical and process connection type
ID	Transmitter model ID
# S/N	Transmitter serial number
	Measuring range
	Supply voltage values
	Output signal
	Permissible range of ambient temperature
	Permissible static Pressure
IP	IP protection rating
Year of production	Year of production
	Note about the obligation to read the manual
//The lower part of the nameplate//	Special execution

5.3. CE mark, declaration of conformity

The device has been designed to meet the highest safety standards, has been tested and has left the factory in a condition that is safe for operation. The device complies with the applicable standards and regulations listed in the EU Declaration of Conformity and has CE marking on nameplate.

6. INSTALLATION

6.1. General recommendations



It is recommended that in case of a gaseous medium, the transmitters should be installed above the measuring point so that condensate may flow to the point from which the measured pressure is collected, while in case of liquid medium or steam, it should be installed below the point of pressure intake. The configuration of impulse tubes and valve connection system should be selected taking into account the measurement conditions.

Differential pressure transmitters for gases PRE-28 should be obligatorily installed vertically. For low measurement ranges, there may be an influence of transmitter's position and influence of impulse lines position and liquid filling method on output signal. Any possible misalignment of the signal should be corrected by resetting the transmitter after mounting.

PCE-28P level probes are installed in places where liquid level is measured. The probe is immersed in the measured medium and the electronic unit with the connector is above its maximum level. The probe pipe, with lengths over 1m, it is advisable to attach it in two places. When installing the probe outdoors, install a canopy or booth over the electronic unit. If the probe is installed in a stream or in a turbulent area, a conduit must be installed → 8.2.

6.1.1. Installation instructions for transmitters with separators

The protection of the separator diaphragm can only be removed shortly before installation.

Hydrostatic pressure of the manometric liquid column in the transmitter - separator system may cause incorrect indication of the measured value. After installation, the transmitter must be pressure-reset → 8.2 (not available for transmitter in ALW, ALM and SG housing).

Do not clean or touch separator diaphragms using hard or pointy objects.

Separators with pressure transmitter form a closed, calibrated system filled with gauge fluid. The opening for filling the device with gauge fluid is sealed and must not be opened.



When choosing a mounting location, it is necessary to ensure sufficient stress relief of the capillaries tension in order to avoid excessive bending.

Incorrect installation of the sealing may result in incorrect measurement indications.

Special attention must be paid when selecting correct dimensions of the sealing.



As standard, the separators are not provided with the gaskets.

7. ELECTRICAL CONNECTION

7.1. Cable connection to transmitter internal terminals



All connection and installation operations shall be performed with disconnected supply voltage and other external voltages, if used.



Failure to provide proper connection of the transmitter may result in danger. Risk of electric shock and/or ignition in potentially explosive atmospheres.

7.1.1. Connection of transmitters with PD type connector

Loosen the screw in the upper part of the connector and the nut that connects the connector to the transmitter housing, the cable outlet can be set in any direction. It is advantageous to form the conduit in the form of a drip loop to prevent condensation from running down towards the gland. Connect the cables in accordance with the marking on the transmitter and Table 2 or Table 3 (depending on the version). A correctly assembled PD connection should have tightened: the gland nut, the connection nut to the steel housing and the screw connecting both parts of the connector

7.1.2. Connection of transmitters with PZ type connector

The electrical connection of the transmitters with the connector should be made by connecting the signal wires to the transmitter terminals. Screw on the cover and the stuffing plug of the gland carefully, making sure that the gasket is tightly compressed on the conduit.

7.1.3. Connection of transmitters with PK, PKD, SG i PM12 type connector (cable connection)

Electrical connections of transmitters equipped with PK, PKD, PM12 and SG type connectors are made through a terminal box with a gland in which the converter cable connects to the further part of the signal line. The terminal box must not be completely airtight, as the transmitter must be able to “breathe” through a capillary in the connector cable. It is recommended to use a Aplisens S.A. PP terminal box.

7.1.4. Connection of transmitters with ALW, ALM type connector

Electrical connections transmitters equipped with ALW type or ALM type connector is the same as connecting transmitters with connectors PD or PM12, depending on the ordered version.

Table 2. Connection for the current version.

Connection for current version			
Connector connection		Cable connection	
Connector number	Type of connector	Wire colour	Type of connector
1	+	Red	+
2	-	Black	-
3	Not supported;	Green	SHIELDED CABLE
⊥	SHIELDED CABLE		

Table 3. Connection for the voltage version.

Connection for voltage version			
Connector connection		Cable connection	
Connector number	Type of connector	Wire colour	Type of connector
1	+	Red	+
2	-	Black	-
3	Voltage	Blue	Voltage
⊥	SHIELDED CABLE	Green	SHIELDED CABLE

7.1.5. Specifications of electrical switching terminals

Internal electrical switching terminals are suitable for conductors with the cross-section from 0,5 to 2,5 mm² (depending on version). The internal and external electrical ground terminal of the body is suitable for conductors with cross-section from 0,5 to 4 mm² (depending on version).

7.1.6. Cabling specification

Aplisens S.A. recommends using two-wire screened twisted pair cable. The outer diameter of the cable shell from 6 to 9 mm (for cable gland PG-9) or from 8 to 10 mm (for cable gland PG-11) is recommended.

7.2. Earthing

Transmitters with PD connections have a ground terminal in the connector, which should not be used for protective grounding or for connecting the equalizing conductor; it is only used for functional grounding. The transmitters with PZ connection are equipped with internal (in Ex version also external) grounding terminals, to which functional or equipotential grounding conductors can be connected. In transmitters with PK, PKD, SG, PM12 cable connections, the cable screens are brought out and remain at the user's disposal. The screen of the cable should be connected on one side with the earthing point of the measuring system. The transmitters with ALW and ALM connections are additionally equipped with an external earthing terminal.

If the transmitter has a galvanic connection via the process connection to a well-grounded metal pipe or vessel, additional functional grounding is not necessary. The grounding terminals in electrical connections are as functional grounding. They should be used when the transmitter is not grounded through the head connection stub. If it is impossible to ground the cable shield at the power supply point and the converter grounded through the head connector, the grounding clamps can be used to connect the cable shield. Functional grounding is to ensure the correct operation of the anti-interference suppression unit of the transmitter. In standard installations, i.e. when the transmitter is grounded through the pipeline, and the possible cable shield is connected to the transmitter's power supply and measurement system, the functional grounding terminal should not be used.

7.3. Overvoltage protection

Transmitter and Electrical connection type	Protection between wires (transil diodes) – nominal voltages	Security between the wires, and ground and / or casing - type protections - nominal voltage
PCE-28, PRE-28, PCE-28P with PD, PK connection	Standard version 36 V DC Exi version 40 V DC	Gas limiter - 230 V DC used in Exi only for "Version SA"
PCE-28 with PZ, PKD, SG, SGM, PM12 connection, ALW, ALM		
Additionally, an external protective device can be used, e.g. the UZ-2 system by APLISENS or others.		

7.4. Shielding, equipotential bonding

In the case of using a cable in the screen, connect the screen on one side at the point where the transmitter is powered.

7.5. Transmitter power supply

7.5.1. Transmitter supply voltage



Power cables may be live.
There is a risk of electric shock and/or explosion.

Table 4. Permissible transmitter supply voltages.

Version and type of transmitter		Output signal	Minimum supply voltage	Maximum supply voltage
Standard Version	– PCE(R)-28	4...20 mA	7 V DC	39 V DC
		0...10 V	13 V DC	30 V DC
	– PCE-28P	4...20 mA	7 V DC	39 V DC
	– PCE-28 ALW/ALM (version with display)		10 V DC	39 V DC
– PCE(R)-28/TR** – PCE-28P/TR**	10,5 V DC*		36 V DC	
Exi Version	– PCE(R)-28 PCE-28P	4...20 mA	9 V DC	28 V DC
			– PCE-28 ALW/ALM (with display)	12 V DC*
	– PCE(R)-28/TR** – PCE-28P/TR**		12 V DC	28 V DC

* Turning on the display backlight in the PCE-28 converters with ALW and ALM type connectors increases the minimum supply voltage for all versions by 3 V. The way to turn the backlight on or off is shown in → [Figure 3](#)
** TR- design for Pressure measurements in fast changing processes.

7.5.2. Resistance load in power supply line

The power line resistance, power source resistance and other additional serial resistances increase the voltage drops between the power source and the transmitter terminals. The maximum current of standard transmitters under normal operation conditions is defined as $I_{max} = 0,02 \text{ A}$, but during high alarm the value of current.

The maximum resistance value in the power circuit (along with the power cables resistance) is defined by the formula:

$$R_{Lmax} \geq 20k\Omega$$

For voltage version

$$R_{Lmax} = \frac{(U_{sup} - U_{min})}{0,02 \text{ A}}$$

For current version

where:

U_{sup} – voltage at the supply terminals of the 4...20 mA current loop [V].

U_{min} – minimum supply voltage of transmitter → [Table 4. Permissible transmitter supply voltages.](#)

R_{Lmax} – maximum power supply line resistance [Ω].

7.6. Final inspection of cabling

After completing the electrical installation of the transmitter it is necessary to check the following:

- Does the supply voltage measured at the transmitter terminals at maximum set current match the range of supply voltage specified on the transmitter nameplate?
- Is the transmitter connected according to the information given in section (→ [Cable connection to transmitter internal terminals](#))?
- Are all the screws tightened?
- Are the transmitter covers tightened?
- Are the cable gland and the gland plug tightened?

8. START-UP

The basic data of the transmitter and probe can be read out from its nameplate (→ [Transmitter identification](#)).



Use the transmitter within the allowable pressure limits. Risk of injury due to component breakage after exceeding the maximum permitted operating pressure.

8.1. Alarm configuration

Analog transmitters have the possibility of setting the low alarm level (about 3 mA) or high (about 25 mA). Alarms indicate damage to the pressure sensor and/or the transmitter analog circuit. The setting of alarms is possible only at the production level according to the customer's order. It is not possible to make changes and configuration of alarms in field conditions.

8.2. Correction of impact of transmitter mounting position on site – pressure reset

After installing the transmitter, you may need to adjust the zero signal. This can be done with a precision screwdriver and a milliammeter, or a millivoltmeter for a pressure transmitter (gauge) with zero adjustable for atmospheric pressure. The adjustment can be made after powering the transmitter, partially disassembling the electrical connection and gaining access to the appropriate potentiometer marked with the symbol "zero". At atmospheric pressure in the installation, use a potentiometer to bring the zero signal to the initial value: 4 mA or 0.05 V depending on the output signal. At other than zero values of the initial pressure, the zero adjustment can only be performed when the pressure at the lower limit of the measuring range is applied to the transmitter input. The zero signal can be adjusted or shifted within 10% of the measuring range width (FSO) from the factory-set value.

9. OPERATION

The transmitter gives the possibility of rotating the housing and adjusting the display position to the mounting position of the body. To rotate the housing, loosen the screw (item 1), position the transmitter housing (item 2) as required, tighten the screw (item 1). Access to the extensions (item 4) used to rotate the display is provided after opening the front cover (item 3).

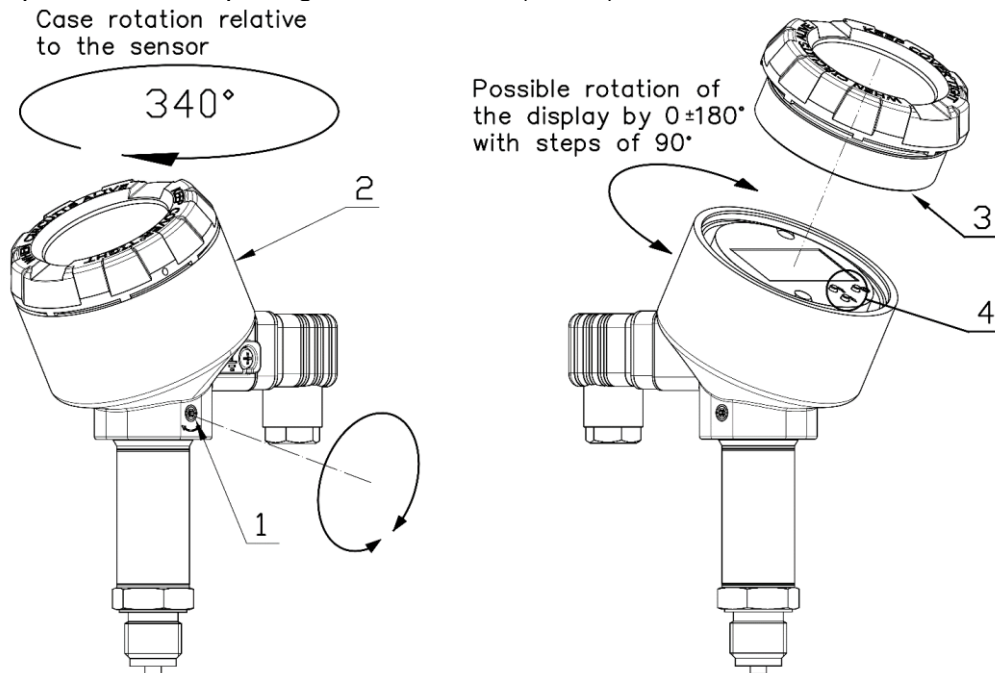

Figure 1. Rotation of the housing, change of display position and access to buttons.

1. Screw.
2. Transmitter housing.
3. Front cover.
4. Buttons.

The LCD has three primary information fields identified in the figure below as LCD1, LCD2, LCD3.

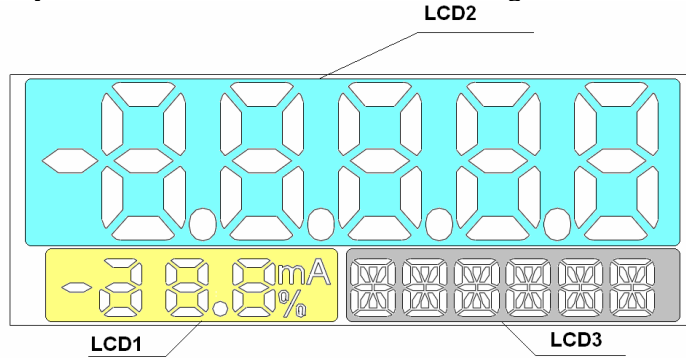

Figure 2. Display information fields.

LCD1 field - display field of current or guidance percent preset range display. Depending on the display configuration will be displayed the current value of the current line 4...20 mA with a resolution 0.1 mA, or percent guidance the preset range with a resolution of indications 1%.

LCD2 field - display field of digital value of measured pressure by transmitter, value of pressure rescaled according to the user's units or the error code. Decimal point position can be set in local MENU.

LCD3 field - information field. During normal operation is designed for continuous display of the base unit or the user units. In case of errors in the transmitter's work, it displays an error number. In manual mode, the local change settings menu displays options of selecting the setting. It also displays errors related to the implementation of commands in the local menu of the settings change.

Backlight (available for versions with display: ALW or ALM) – local display is equipped in backlight which can be switched on or off depending on needs. Turn on the backlight increases the minimum supply voltage for all version of 3V. Enable or disable the backlight is possible using the jumper after removing the back cover of the display. Enable or disable backlight is shown in Figure 3.

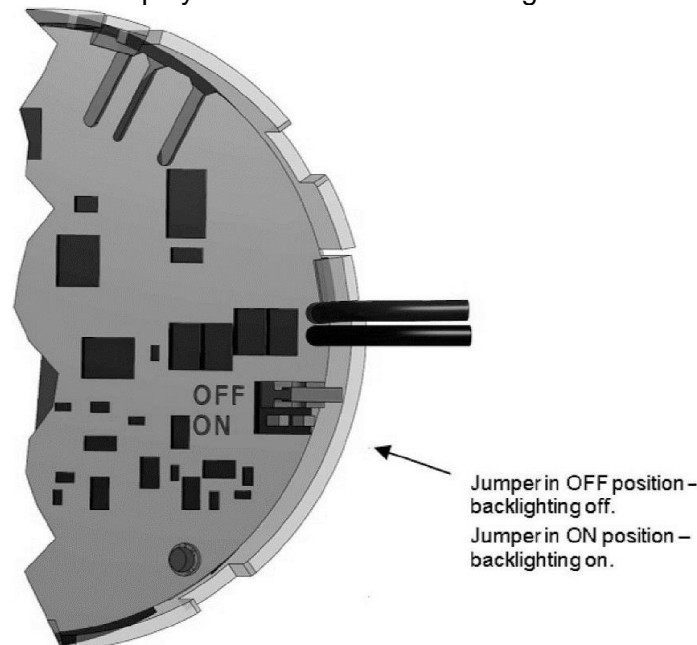

Figure 3. Backlighting jumper view at transmitter electric board (unit display back side).

Abbreviations of physical units of pressures and levels and their description:

INH2O	inches of water column with temperature of 0°C.	KGSQCM	kilograms per square centimeter.
INGH	inches of mercury column with temperature of 0°C.	PA	pascals.
FTH2O	feet of water column with temperature of 20°C (68°F).	KPA	kilopascals.
MMH2O	millimeters of water column with temperature of 20°C (68°F).	TORR	torrs.
MMHG	millimeters of mercury column with temperature of 0°C.	ATM	atmosphere.
PSI	pounds per square inch.	MH2O4	metres of water column with temperature of 4°C.
BAR	bars.	MPA	megapascals.
MBAR	millibars.	INH2O4	inches of water column with temperature of 4°C.
GSQCM	grams per square centimeter.	MMH2O4	millimeters of water column with temperature of 4°C.

Abbreviations displayed during configuration via local MENU and their descriptions:

<-BACK	return to one level above in local MENU.
EXIT	going out of the local MENU.
UNIT	pressure and level unit selection menu.
TEMP	menu of selecting temperature
MISC	menu of selecting others units
SETLRV	the function allows you to assign a specific value to the 4 mA current.
SETLRV	the function allows you to assign a specific value to the 20 mA current
RESET	transmitter hot restart software menu
XX.XXX UNIT	the function displays the current value of the beginning or the end of the displayed range. The confirmation of the option makes it possible to assign a specific value to the beginning or the end of the set range
+/-	entering the value of the set range. The character is selected by pressing "↑" or "↓". The addition of the digit is done by confirming the previous one and pressing the [•] button. The comma is set after the 6th character of the parameter is confirmed. The device will confirm the acceptance of the command with the message "DONE" or report an error number. The parameter is entered in UNIT units.
LCD2DP	Changing the position of the decimal point of the variable displayed in the LCD2 field of the display.
X.XXXX	option of selecting position of comma/decimal point.
XX.XXX	option of selecting position of comma/decimal point.
XXX.XX	option of selecting position of comma/decimal point.
XXXX.X	option of selecting position of comma/decimal point.
XXXXX.	option of selecting position of comma/decimal point.
DONE	The message of acceptance and execution of the setting change.
FILTER	Selection of the averaging time of the displayed process variable.
LCD1VR	Process variable type displayed in the LCD1 field of the display.
CURREN	The value of the current in the loop will appear on the display in the LCD1 field.
PERCEN	The percentage value of the output activation will appear on the display in the field view.

9.1. Local buttons

Local buttons are used to enable the configuration mode of some transmitter parameters and to navigate through MENU and accept MENU options. The MENU can be accessed by pressing and holding any of the buttons for at least 4 seconds. After this time, the LCD3 field of the local display will show an **EXIT** message. This signals entering into the MENU navigation mode.

9.2. Local configuration of setpoints

Transmitter enables local configuration of some of the most common setpoints via local buttons and local LCD display (available for ALW and ALM housing version).

9.3. Navigation in local setpoints MENU

The MENU can be accessed by pressing and holding any of the buttons for at least 4 seconds. After this time, the LCD3 field of the local display will show an **EXIT** message. This signals entering into the local configuration MENU. By pressing the buttons with arrows [↑] [↓] for at least 1 second you can move up or down in MENU.

9.4. Acceptance of local setpoints

The button marked with symbol [●] is used to accept the selection. The acceptance of setpoint change is confirmed by a **DONE** message displayed on LCD3. After changing the setpoint, the transmitter leaves the local configuration change MENU. If no selection is made in the MENU mode, after 2 minutes the transmitter automatically returns to display of standard messages. The MENU can also be left by selecting and accepting the **EXIT** option.

9.5. Structure of local setpoints MENU

Press and hold any of 3 buttons for 4 seconds.

When navigating in the area of the active local MENU, holding the button required to trigger the action is minimum 1 second. Continuous pressing of the ↑ or ↓ button results in scrolling of the MENU positions every 1 second. If the local MENU remains inactive for more than 2 minutes, after this time the transmitter will automatically leave the MENU mode and will display the process variable.

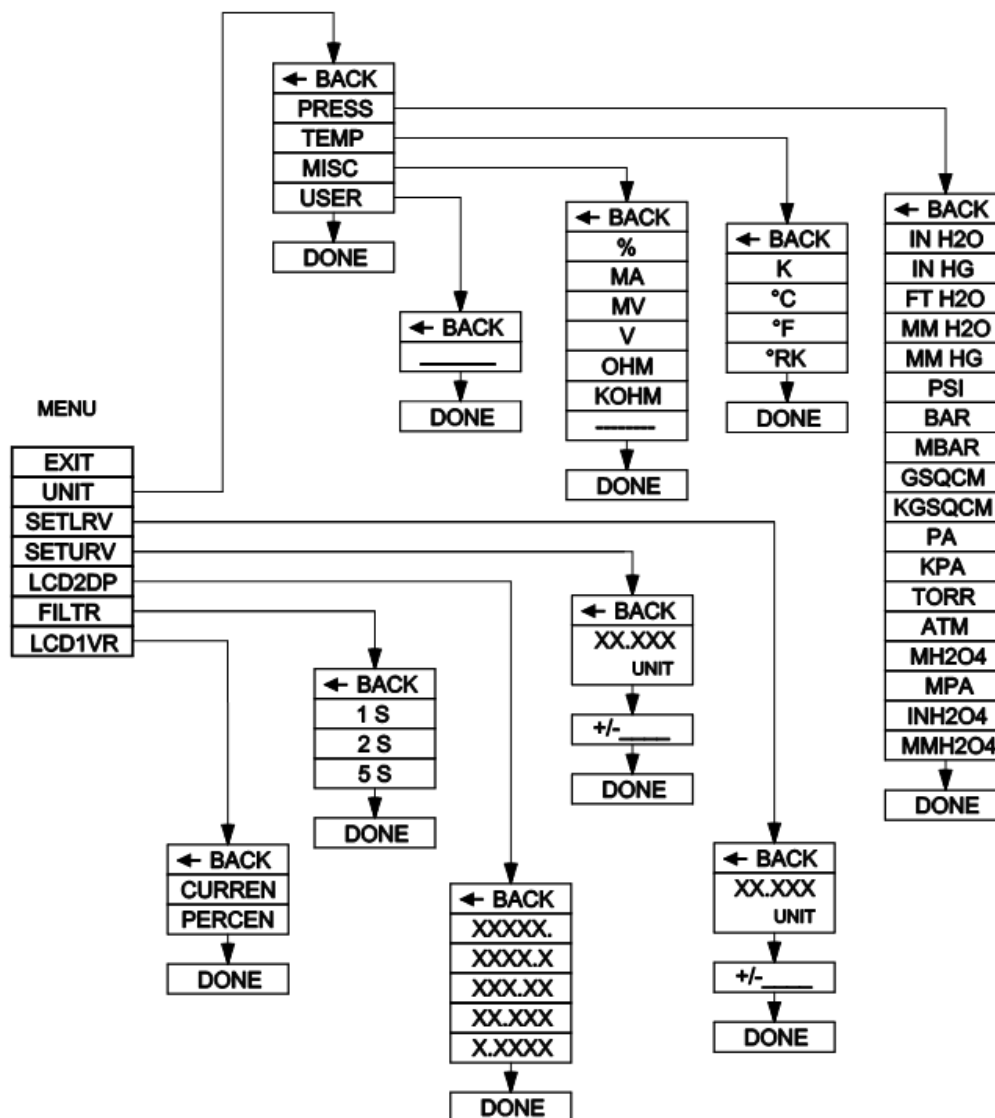

Figure 4. Diagram of the display menu (applies to ALW and ALM versions).

10. MAINTENANCE

10.1. Periodic inspections

Periodic inspections shall be carried out in accordance with applicable standards. During the inspection, the condition of the pressure (absence of loosened elements and leaks) and electrical (check of connections reliability and condition of gaskets and glands) connectors, condition of separating diaphragms (tarnish, corrosion) and stability of fixing of the housing and mounting bracket (if used) shall be checked. Check the processing characteristics by performing the operations specific for the CALIBRATION and possibly CONFIGURATION procedure.

10.2. Non-periodic inspections

If the transmitter at the installation site has been exposed to mechanical damage, pressure overload, hydraulic pulses, overvoltage, deposits, medium crystallization, undercutting of the diaphragm, or incorrect operation of the transmitter is detected, the device should be inspected. Check the condition of the diaphragm, clean it, check the electrical functionality of the transmitter and the processing characteristics.



If there is no signal in the transmission line or its value is improper, check the supply line, connection status on terminal blocks, connectors, etc. Check if the supply voltage and load resistance are correct.

10.3. Cleaning/washing

To remove impurities from the external surfaces of the transmitter wipe it with a cloth dampened in water.

10.3.1. Diaphragm cleaning

The only possible method of cleaning the transmitter diaphragms is to dissolve the sludge produced.



Do not remove deposits and impurities from the transmitter diaphragms, which are formed during operation, mechanically using tools, since the diaphragms and the transmitter can be damaged.

10.4. Spare parts

Parts of the transmitter that may be worn or damaged and thus replaced:

- Transmitters with PD connector: terminal block with angular cover and gasket, and connect or base with gasket;
- In the transmitter with PK, PKD connection - all connections;
- In the transmitter with PZ connector - cover gasket and gland, electrical connection plate with a cover;
- In the transmitter with PM12 connection - PM12 connector;
- In the transmitter with ALW or ALM connection - cover gasket and PD or PM12 connector.



Other parts in the case of ATEX, PED type of transmitter may be replaced only by the manufacturer or an authorized representative.

10.5. Repair

Faulty or non-operational transmitter shall be provided to the manufacturer or an authorized representative.

10.6. Returns

In the following cases, the transmitter should be returned directly to the manufacturer:

- need for repair;
- need for factory calibration;
- replacement of improperly selected/shipped transmitter.

11. SCRAPPING, DISPOSAL



Worn or damaged devices shall be scrapped in accordance with WEEE Directive (2012/19/EU) on waste electrical and electronic equipment or returned to the manufacturer.

12. HISTORY OF REVISIONS

Revision No.	Document revision	Description of changes
-	Revision F/2018.02	Introduction of the directive ROHS editorial changes.
1	Revision G/2019.01	Updating maritime certificates.
2	Revision H/2020.01	Updating data of PED certificate.
3	01.A.001/2021.06	Initial document version. Replaces the revision H Change of electronics, updates of supply voltages. Editorial changes. Prepared by DBFD.

I. APPENDIX Ex.01

PRESSURE TRANSMITTERS TYPE: PC-28/XX/YY,
 DIFFERENTIAL PRESSURE TRANSMITTERS TYPE: PR-28/XX/YY,
 HYDROSTATIC LEVEL PROBES TYPE: PC-28P/XX/YY,
 INTRINSICALLY SAFE VERSION acc. to ATEX and IECEx.

1. Introduction

The "Appendix Ex.01" to EN.PCE.PRE-28.02 applies to PCE-28/XX/YY, PCE-28P/XX/YY and PRE-28/XX/YY transmitters in intrinsically safe version according to ATEX and IECEx marked on the rating plate as shown in p. 2. Extensions XX, YY after the marking product types apply to the types of pressure (XX) and electrical (YY) connections and will not occur later in the documentation.

The appendix contains supplementary information relating to the Ex version transmitters.

During installation and use of the intrinsically safe transmitters, reference should be made to EN.PCE.PRE.28 together with "Appendix Ex.01".

In the case of Ex transmitters with diaphragm seals, the "IO.SEPARATORS" manual should also be used.

2. Using of PCE-28, PCE-28P, PRE-28 in hazardous areas

The transmitters are produced in accordance with the requirements of the following standards: EN 60079-0:2012+A11:2013 (IEC 60079-0:2012), EN 60079-11:2012 (IEC 60079-11:2011), EN 50303:2000.

The transmitters with PD, PK, PKM, PZ, SG, SGM electrical connection may operate in areas where there is a risk of explosion, in accordance with the rating of the explosion protection design:

ATEX:



I M1 Ex ia Ma
 II 1/2G Ex ia IIC T4/T5/T6 Ga/Gb
 II 1D Ex ia IIIC T110°C Da
 FTZÚ 12 ATEX 0193X

IECEx:

Ex ia Ma
 Ex ia IIC T4/T5/T6 Ga/Gb
 Ex ia IIIC T110°C Da
 IECEx FTZÚ 13.0004X

The transmitters with PKD and PM12 electrical connection are permitted only for potentially explosive gas atmospheres and are marked:

ATEX:



1/2G Ex ia IIC T4/T5/T6 Ga/Gb
 FTZÚ 12 ATEX 0193X

IECEx:

Ex ia IIC T4/T5/T6 Ga/Gb
 IECEx FTZÚ 13.0004X

The transmitters with ALW and ALM electrical connection are permitted for potentially explosive gas and dust atmospheres and are marked:

ATEX:



I 1/2G Ex ia IIC T4 Ga/Gb (z PD or PM12)
 II 1D Ex ia IIIC T110°C Da (with connector PD)
 FTZÚ 12 ATEX 0193X

IECEx:

Ex ia IIC T4 Ga/Gb (z PD or PM12)
 Ex ia IIIC T110°C Da (with connector PD)
 IECEx FTZÚ 13.0004X

3. Permissible input parameters (based on data from the FTZU 12 ATEX 0193X certificates and IECEx FTZÚ 13.0004X)



The transmitters should be powered from cooperating power supply and measurement de-vices with relevant intrinsically safe certificates, the parameters of which outputs to the hazardous area should not exceed the permissible supply parameters for the transmitters specified in items a) and b). Transducers in "SA" version and transmitters operating in the dust zone area should be supplied from devices with a galvanically separated power supply. If it is not possible to use a galvanically separated power supply, the transmitter or any metal parts connected to it should be properly earthed, e.g. using an equipotential bonding system or an equipotential bonding between the transmitter and the negative terminal of the power supply barrier.

The pressure transmitter is an intrinsically safe device with the "ia" protection level, when the supply circuit has the "ia" protection level.

a) Permissible input parameters for power supply with a linear output characteristic:

$$U_i = 28 \text{ V DC}; \quad I_i = 0.1 \text{ A}; \quad P_i = 0.7 \text{ W}$$

b) Permissible input parameters for power supply with a trapezoidal and rectangular output characteristic:

$$U_i = 24 \text{ V DC}; \quad I_i = 0.1 \text{ A}; \quad P_i = 1.2 \text{ W}$$

c) Input inductance and capacity: $C_i = 25 \text{ nF}^*$; $L_i = 0.4 \text{ mH}^*$

* One should take into account the capacity and inductance of the cable, which permanently connected cable are: $C_K = 0.2 \text{ nF/m}$ and $L_K = 1 \text{ }\mu\text{H/m}$.

Input capacitance C_W and input inductance L_W of the transmitters with PK, PKM, SG, or SGM electrical connections, taking into account the parameters of the permanently connected cable are accordingly:

$$C_W = C_i + a \cdot C_K = 25 \text{ nF} + a \cdot 0.2 \text{ nF/m}$$

$$L_W = L_i + a \cdot L_K = 400 \text{ }\mu\text{H} + a \cdot 1 \text{ }\mu\text{H/m}$$

Where:

a - length of the mounted permanently cable in meters;

Ta = -40°C to ... - see table Z1

Table Z1. Temperature classes and maximum surface temperature for group III

Pi [W]	Ta [°C]	Temperature class
0,7	45	T6
	80	T5, T4, group I, group III - 110°C
1,2	75	T5
	80	T4, group I, group III - 110°C

Special conditions for safe use:

- Ambient temperature range from Ta = -40°C to...- see table Z1.
- Process temperature (medium) at the diaphragm of the transmitter must be in range of ambient temperature.
- In case of use the transmitter in dust atmosphere, supplying voltage could occur on transmitter housing. It should be taken into consideration during transmitter installation.
- In case of use titan parts in diaphragm seal, during installation and operation of the device the diaphragm seal should be protected against mechanical impact.
- Version of transmitter with surge arrester, marked on the plate "Version SA", does not meet the requirements of Section 6.3.13 of the EN 60079-11:2012 (test of isolation 500 V AC). This must be taken into consideration during the installation of transmitter.
- Transmitters with display (with electrical connections ALW, ALM) and with diaphragm seals covered by PTFE, for Group III, should be installed in a place and in a way that prevents electrostatic charging.



At the customer's request, elements of diaphragm seal can be made of titanium. This version of the transmitter has information on the label that the titanium elements are used (e.g. PCE-28/S-Ch titan/PD). Then user should secure the diaphragm seal against the possibility of an impact.

When medium temperature is higher than ambient temperature - Ta, use of separating elements such a diaphragm seal, or looped siphon tube etc. is necessary. The process temperature (medium) at the diaphragm of the transmitter must be within the ambient temperature range.

APPENDIX Ex.01

4. Electrostatic hazards

A plastic nameplate, a light alloy housing varnish, a Teflon layer covering the elements of the transmitter diaphragm seal, a Teflon cable sheath and a heat-shrinkable sheath applied to a metal capillary constitute a non-conductive layer applied to the conductive substrate. Such transmitters, in dust explosion hazard zones, should be installed in a way that prevents electrostatic charging, in particular through contact with electrified dust falling off or blown from devices operating nearby.

5. How to connect Ex transmitters Ex: PCE-28, PCE-28P and PRE-28



Connections of the transmitter and devices in the transmitter measuring loop should be made in accordance with the intrinsic safety and explosion-proof standards and the conditions of use in hazardous areas. Failure to follow these rules may result in an explosion and hazards to workers.

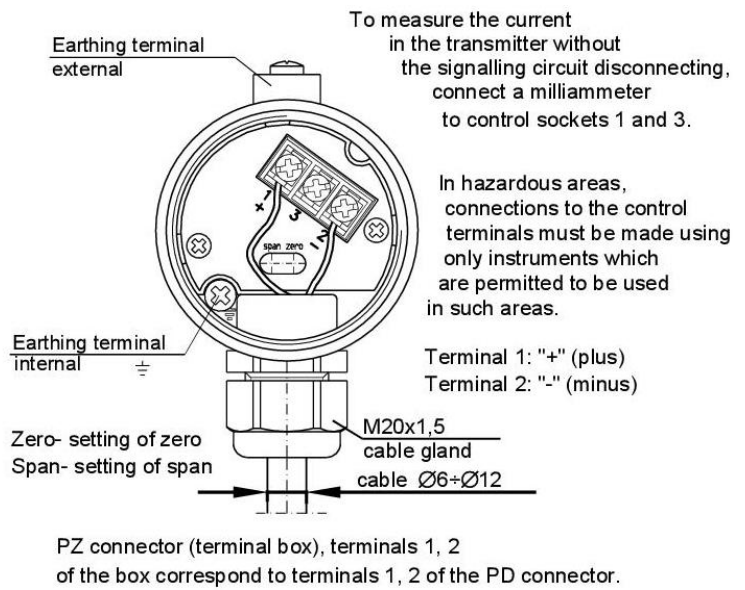
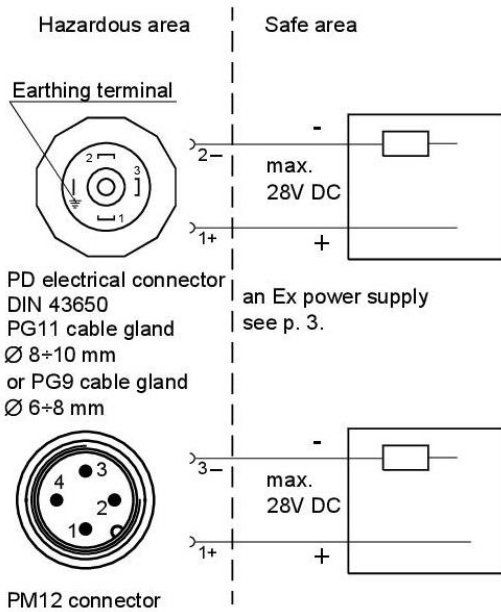

Figure 1. Connection of the transmitter with PD and PM12 electrical connectors.

Figure 2. Connection of the transmitter with PZ electrical connector.

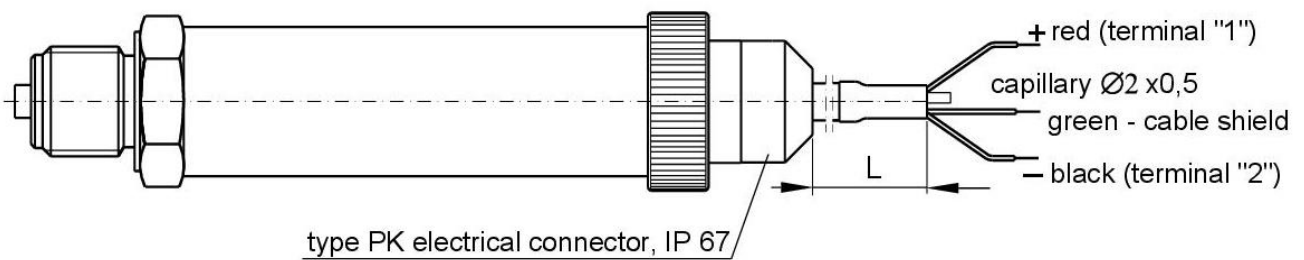

Figure 3. Connection of the transmitter with PK electrical connector.

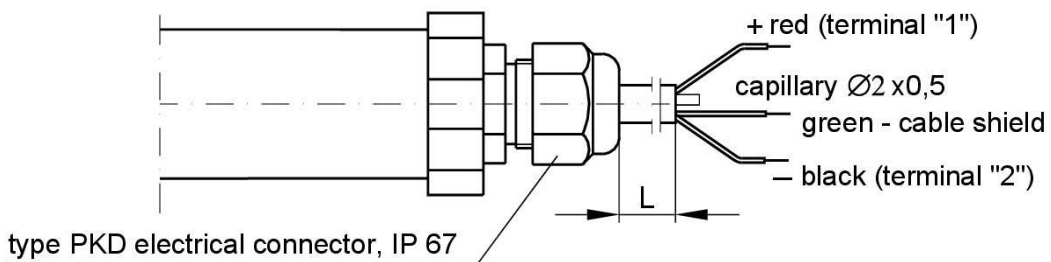

Figure 4. Connection of the transmitter with PKD electrical connector.

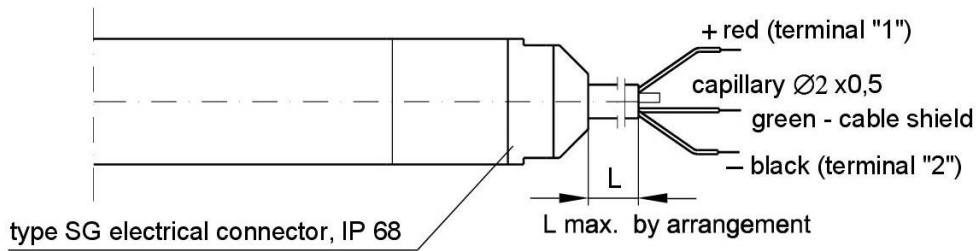

Figure 5. Connection of the transmitter with PKD electrical connector.

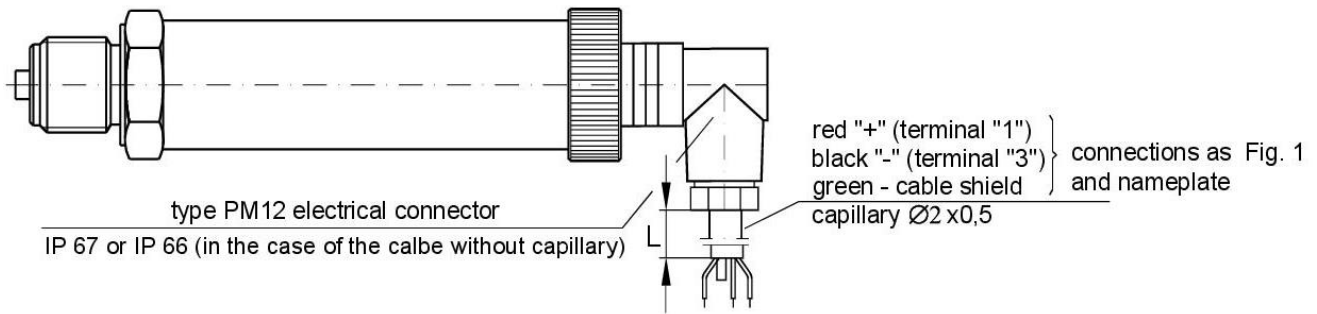

Figure 6. Connection of the transmitter with PM12 electrical connector.

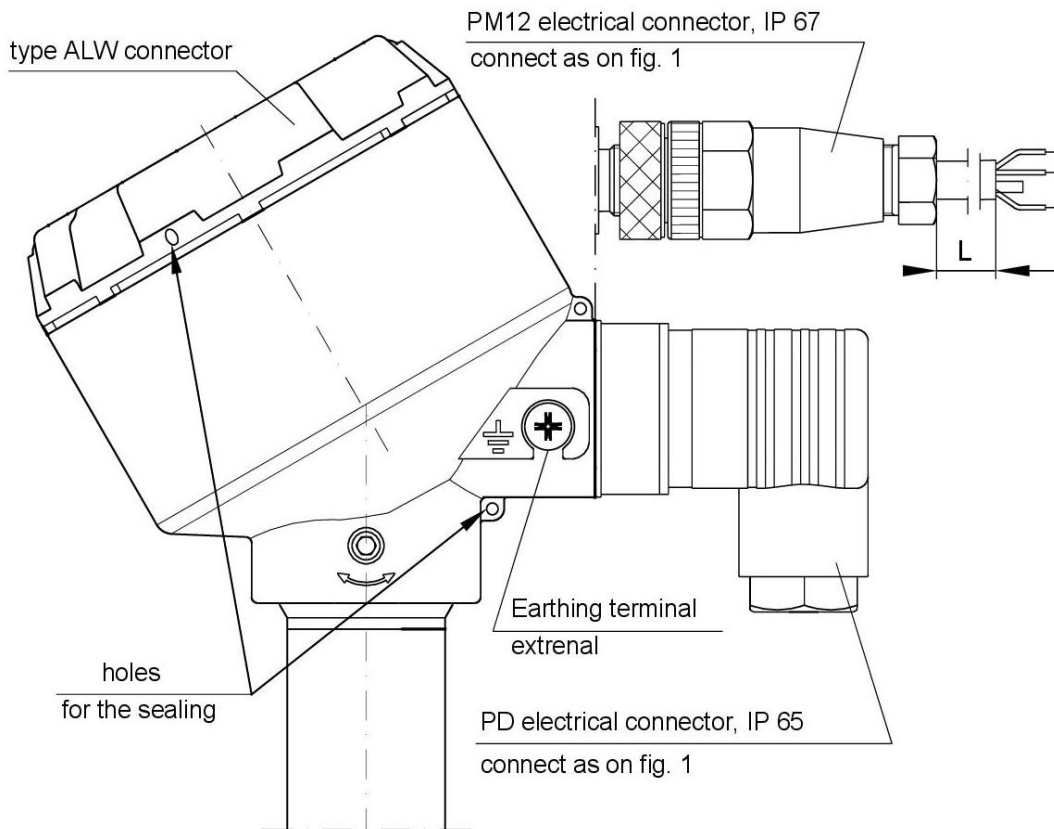

Figure 7. Connection of the transmitter with ALW electrical connector.

APPENDIX Ex.01

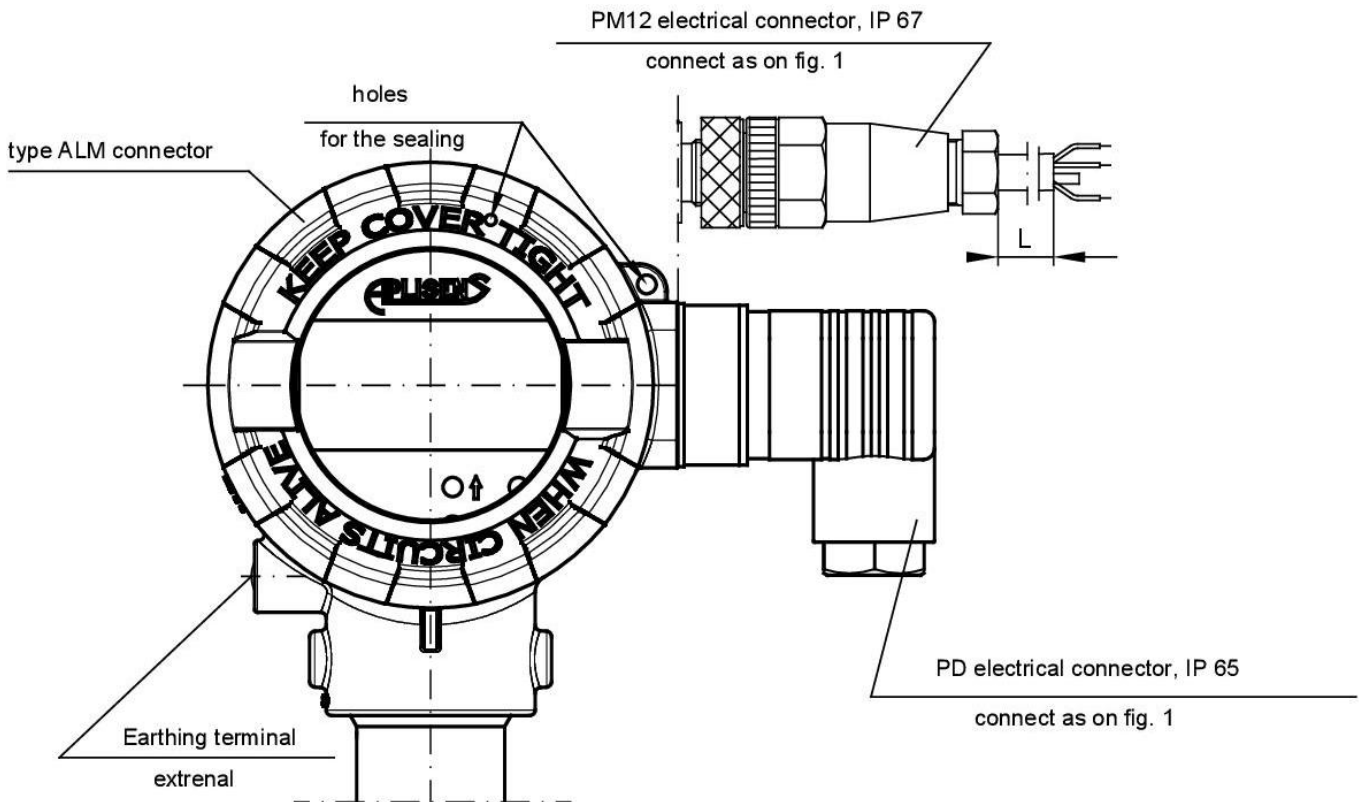

Figure 8. Connection of the transmitter with ALM electrical connector.



It is not allowed to repair or otherwise interfere with the transmitter's electrical circuits in any way.
 Damage and possible repair can be assessed and done by the manufactures or another authorised party only.

II. APPENDIX Ex.02

PRESSURE TRANSMITTER TYPE: PCE-28/TR/XX/YY, PC-28P/TR/XX/YY,
 DIFFERENTIAL PRESSURE TRANSMITTER TYPE: PRE-28/TR/XX/YY,
 HYDROSTATIC LEVEL PROBES TYPE: PCE-28P/TR/XX/YY,
 INTRINSICALLY SAFE VERSION acc. to ATEX **KDB 08ATEX002X**

1. Introduction

The "Appendix Ex.01" to EN.IO.PCE.PRE.28 applies to PCE-28/XX/YY, PCE-28P/XX/YY and PRE-28/XX/YY transmitters in Ex version according to ATEX marked on the rating plate as shown in p. 2 and 3 and signed "Ex" in the Product Certificate, only.

Extensions XX, YY after the marking product types apply to the types of pressure (XX) and electrical (YY) connections and will not occur later in the documentation.

The appendix contains supplementary information relating to the Ex version transmitters.

During installation and use of the Ex transmitters, reference should be made to EN.IO.PCE.PRE.28 together with "Appendix Ex.02".

2. Using PCE-28, PRE-28,PCE-28P transmitters in hazardous area

The transmitters are produced in accordance with the requirements of the following standards:

EN 60079-0:2013, EN 60079-11:2012, EN 50303:2000

The transmitters may operate in areas where there is a risk of explosion, in accordance with the rating of the explosion protection design:

 I M1 Ex ia I Ma
 II 1/2G Ex ia IIC T4/T5/T6 Ga/Gb
 II 1D Ex ia IIIC T110°C Da
KDB 08ATEX002X

3. Permissible input parameters (based on data from the ATEX KDB 08ATEX002X)



The transmitters should be supplied from cooperating power supply and measurement devices with relevant intrinsically safe certificates, the parameters of which outputs to the hazardous area should not exceed the permissible supply parameters for transmitters specified in items a) and b).



The pressure transmitter is an intrinsically safe device with the "ia" protection level, when the supply circuit has the "ia" protection level.

a) Permissible input parameters for power supply with a linear output characteristic:

$U_i = 28 \text{ V DC}$; $I_i = 0.1 \text{ A}$

b) Permissible input parameters for power supply with a trapezoidal and rectangular output characteristic

$U_i = 24 \text{ V DC}$; $I_i = 0.1 \text{ A}$

c) Input inductance and capacity: $C_i = 25 \text{ nF}$; $L_i = 0.4 \text{ mH}$

P_i for all type of power supply – see Table Z2

Table Z2. Temperature classes and maximum Surface temperature for group III.

Pi[W]	Ta [°C]	Temperature class
0,7	45	T6
	80	T5, T4, group I, group III - 110°C
0,9	80	T5, T4, group I, group III - 110°C
	75	T5
1,2	80	T4 group I, group III - 110°C

APPENDIX Ex.02

Special conditions for safe use:

If titanium parts are used in the structure of the separator, the diaphragm seal should be protected against mechanical damage during installation and operation of the transmitter.



At the customer's request, the separator elements can be made of titanium. This version of the transmitter has information on the plate that a separator with titanium elements was used (e.g. PCE-28 / TR / S-Ch titanium / PD). In this case, the user is obliged to protect the separator against the possibility of impact.



The process temperature at the transmitter diaphragm must be within the transmitter operating temperature range and the temperature class. In the case of measuring the medium causing the transmitter to heat up above the operating temperature range, use separating elements, e.g. diaphragm seals (see - IO-SEPARATORS), loop-siphon tubes, etc.

4. Supply examples**4.1. Power supply with a linear output characteristic**

Power supply with a linear characteristic may be e.g. a typical barrier with parameters $U_o = 28 \text{ V}$; $I_o = 0.093 \text{ A}$; $R_w = 300 \Omega$;

4.2. Power supply with a trapezoidal output characteristic

Supply parameters, for example - $T_a \leq 80^\circ\text{C}$ and T4:

a) $U_o = 24 \text{ V}$; $I_o = 0.08 \text{ A}$; $P_o = 1.2 \text{ W}$

b) $U_o = 24 \text{ V}$; $I_o = 0.05 \text{ A}$; $P_o = 0.6 \text{ W}$

4.3. Power supply with rectangular output characteristic

$U_o = 24 \text{ V}$; $I_o = 0.05 \text{ A}$; $P_o = 1.2 \text{ W}$

5. How to connect Ex transmitters: PCE-28/TR, PCE-28P/TR and PRE-28/TR

- acc. to p. 4 and 5 EN.IO.PCE.PRE.28 APPENDIX Ex.01