

DIFFERENTIAL PRESSURE TRANSMITTER for low ranges PRE-50G

- ✓ Measuring range start from 250Pa
- ✓ Output signal: 4-20mA

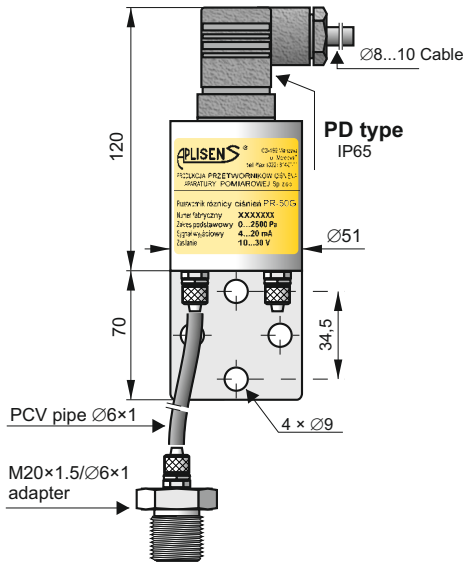

PRE-50G Economic Version, process connection with terminal connecting to Ø6 pipe (**PCV type**) An example with **PD type** Electrical Connection

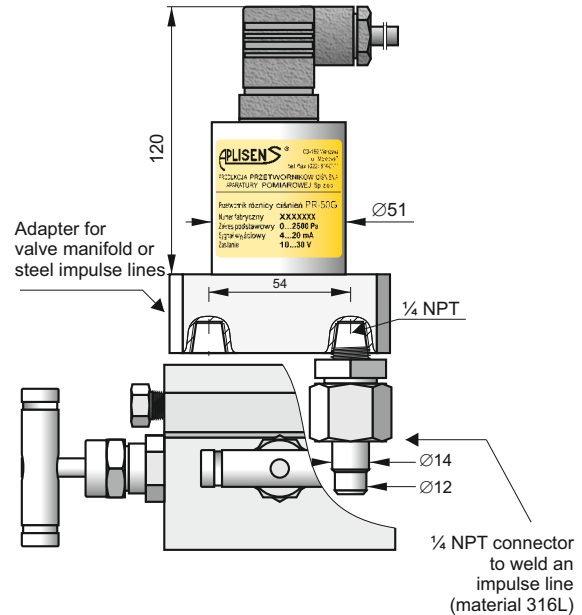

PRE-50G Industrial Version, C type process Connector to be mounted along with a valve manifold

Application

The PRE-50G transmitter is applicable to gases, to the measurements of their pressure, underpressure and differential pressure. Typical applications include the measurement of blast pressure, chimney draughts or pressure / underpressure in furnace chambers. IP protection IP65.

Installation

The economical version can be mounted on any stable construction using the assembly fixture with Ø9 opening. The transmitter's connection shanks have terminals to be connected to the elastic Ø6x1 impulse line. Where the pulse comes through a metal pipe, we suggest an M20x1.5 adapter for a Ø6x1 fitting using.

The transmitter with a C type connector should be mounted on a 3- or 5-valve manifold. We recommend to use our pre-assembled transmitters with VM type valves (page IV/ 2).

Technical data

Any measuring range

250 Pa ÷ 20 kPa

	Measuring range			
	250 Pa	>250...700Pa	>700...2500 Pa	>2500 Pa
Overpressure limit				
Static pressure limit (repeated – without histeresis)	35 kPa	35 kPa	100 kPa	100 kPa
Accuracy	1,6%	0,6%		0,3%
Thermal error 10°C	1%	0,6%	0,3%	

Hysteresis, repeatability 0,05% to 0,25%
depend on setting range

Thermal compensation range 5 ÷ 50°C

Operating temperature range -25 ÷ 80°C

Standard measuring range : 0...250; 0...500 Pa;
0...2; 0...5; 0...10 kPa;
-150...150; -250...250 Pa;
-0,5...0,5; -1...1; -2,5...2,5; -5...5; -10...10 kPa

Output signal 4 ÷ 20 mA two wire transmission
0 ÷ 10 V three wire transmission

Power supply 10...36 VDC two wire transmission
13...39 VDC three wire transmission

Error due to supply voltage changes 0,005% / V

Load resistance (for current output) $R[\Omega] \leq \frac{U_{sup}[V] - 10V}{0,02A}$

Load resistance (for supply output) $R \geq 20k\Omega$

Housing material 0H18N9 (SS304)

Adapters material C - SS316Ti

M20×1,5/Ø6×1 – brass

Valve manifolds SS316

Ordering procedure

Model	Code	Description
PRE-50G		Differential pressure transmitter
Measuring set range	/...+... [required units]	Calibrated range in relation to 4mA and 20mA output
Casing	/PD.....	Housing IP65 with DIN EN 175301-803 connector
Process connections	/PCV.....	Process connection with terminal connecting for Ø6mm elastic pipe. Mounting bracket for wall mounting is a standard.
	/C.....	Thread 1/4NPT F on the cover flanges, diaphragms material SS316L, cover flanges material SS316. Allows mounting with a valve manifold.
Accessories	/M20x1,5/Ø6.....	Adapter from Ø6mm elastic pipe for M20x1,5 M thread (only version with PCV process connection)
	/RedSpaw C.....	Connector to weld impulse pipes dia. 12 and 14 mm, material 15HM. (only version with process connection C type)
	/+VM-3/A.....	Assembled with a 3-way valve manifold (further specification of manifold - see data sheet) . Only version with C type process connection.
	/+VM-5/A.....	Assembled with a 5-way valve manifold (further specification of manifold - see data sheet) . Only version with C type process connection.
Other specification	/.....	Description of required parameters (e.g. non-standard pr. connection G3/4", M22x1,5)

Example: Differential pressure transmitter PRE-50G / range 0...1 kPa / output signal 4 ÷ 20 mA / process connection type PCV. adapter M20×1,5/Ø6×1 X 2 pcs.

PRE-50G / 0 ÷ 1 kPa / 4 ÷ 20 mA / PCV /2x adapter M20×1,5/Ø6×1