

# Flanged seals with extended diaphragm and direct diaphragm cleaning system S-TK-P

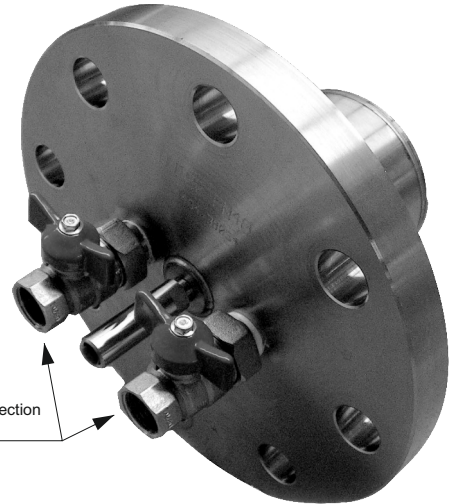

G1/2" ball valves for water connection (max. pressure 16 bar)

### Application

S-TK-P diaphragm seals are special execution of flanged seals with extended diaphragm S-TK-DN100 PN40/T=50mm or T=100m with additional diaphragm cleaning system.

S-TK-P are applicable to the measurement of very viscous medium. Cleaning system allows to clean membrane without dismounting diaphragm seal from the application.

Cleaning medium (e.g. water) is supplied to the membrane surface via two channels placed inside the diaphragm seal.

Cleaning is performed periodically with intervals suitable to the measured medium. Flushing channels are ended with two G1/2" ball valves in the back of diaphragm seal.

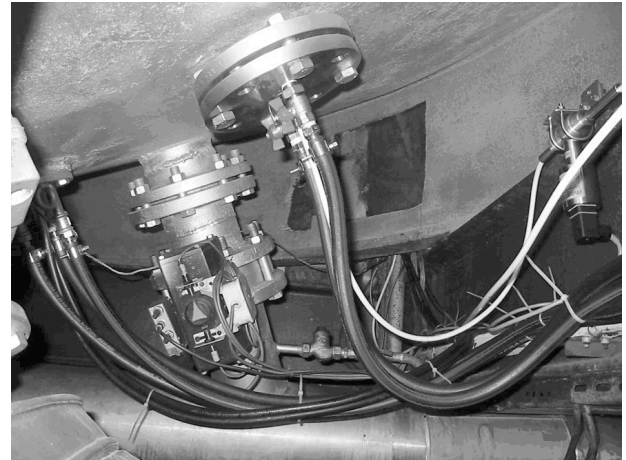

### Ordering procedure

| Model                 | Code        | Description   |
|-----------------------|-------------|---|
| S-TK-P                |             | Direct diaphragm seal with direct cleaning system, flange size DN100 PN40 |
| tube extension length | /T=50.....  | 50mm extension  |
|                       | /T=100..... | 100mm extension   |
| capillary length      | /K=.....    | Input required capillary length in [m]                                    |